

INDEX

| | |
|--|------|
| Micro Hardness Testing Machines | |
| HM-211 / 221 | L-2 |
| HM-101 / 102 / 103 / 112 / 113 | L-4 |
| Vickers Hardness Testing Machines | |
| AVK-CO, HV-112 / 113 / 114 / 115 | L-5 |
| VLPAK2000 | L-6 |
| AT-400 | L-6 |
| AAV-500 | L-7 |
| Rockwell Hardness Testing Machines | |
| HR-511 / 521 / 522 / 523 | L-8 |
| HR-110MR / 210MR / 320MS / 430MR / 430MS | L-9 |
| Micro Zone Test System | |
| MZT-500 | L-10 |
| Brinell Hardness Testing Machines | |
| ABK-1 | L-10 |
| Shore Hardness Testing Machines | |
| ASH | L-11 |
| Portable Hardness Testing Instruments | |
| Hardmatic HH-411 | L-12 |
| Hardmatic HH-300 | L-13 |



Micro Hardness Testing Machines

Rockwell Hardness Testing Machines

Micro Zone Test System

Portable Hardness Testing Instruments

HARDMATIC HH-411

Wizhard HR-500

HM-211 / 221

SERIES 810 — Micro Hardness Testing Machines

FEATURES

- The latest electromagnetic force motor used in the loading mechanism enables the test force to be freely selected (see test force specifications over the wide range of 0.4903mN to 19810mN. It is also possible to freely set the time for loading and load dwell time. Now your desire for absolute control over the indentation size in Vickers hardness testing can be satisfied. The HM-200 series always offers the test force most appropriate for the specimen material and shape.
- It is possible to perform not only the Vickers hardness test but also a fracture toughness test (IF test: JIS R 1607-1995) on ceramics.
- The objectives used enable a very comfortable working distance between the objective and the specimen surface. This greatly reduces the possibility of collision between the specimen and the objective during focusing operations. (e.g. 1.1mm for 50X objective)
- The contrast that is most appropriate for the magnification of the objective can be obtained by manipulating the variable aperture stop in the illumination unit. This makes the indentations clearly visible, leading to less variation and reducing the chance of error when measuring the diagonal lengths.



HM-211



Power turret with 2 indenter mounts and 4 objective mounts (manual operation possible)

Touch-screen switch type control panel



SPECIFICATIONS

| Model No. | HM-211 | HM-221 |
|--|---|--|
| Order No. | 810-352* | 810-353* |
| Fixed test force | mN 98.07 196.1 294.2 490.3 980.7 mN 1961 2942 4903 9807 | 0.4903 0.9807 1.961 2.942 4.903 9.807 19.61 29.42 49.03 98.07 196.1 294.2 490.3 980.7 1961 2942 4903 9807 19610 |
| Arbitrary test force (One type of setting can be saved.) | Test force of 980.7mN or less can be set in increments of 9.807mN Test force of 980.7mN or more can be set in increments of 98.07mN. | Only a test force of 0.4903mN is available below 0.9807mN. Test force of 0.9807mN or more and below 9.807mN can be set in increments of 0.9807mN. Test force of 9.807mN or more and below 98.07mN can be set in increments of 9.807mN. Test force of 98.07mN or more can be set in increments of 98.07mN. |
| Test force control | Force generation by electromagnetic and automatic control (load, dwell, unload) | |
| Control unit | Touch-screen type | Touch-screen type |
| Video monitor | — | — |
| Indenter/objective turret | Motor driven and manual operation | Motor driven and manual operation |
| Indenter mounts | 2 (Vickers indenter is standard accessory) | 2 (Vickers indenter is standard accessory) |
| Objective mounts | 4 (10X and 50X are standard accessories) | 4 (10X, 50X and 100X are standard accessories) |

* To denote your AC power cable add the following suffixes to the order No.:
A for UUCSA, **C** for Taiwan, **D** for CEE, **DC** for CCC, **E** for BS, **F** for SAA, **K** for EK, **No suffix** is required for JIS/100V

Technical Data

| | |
|----------------------------|--|
| Test force range: | HM-211: 98.07mN to 980.7mN (9.807mN increments) 980.7mN to 9807mN (98.07mN increments) 0.4903mN HM-221: 0.9807mN to 9.807mN (0.9807mN increments) 9.807mN to 980.7mN (9.807mN increments) 980.7mN to 19610mN (98.07mN increments) |
| Test force generation: | Electromagnetic |
| Load control: | Automatic (load, dwell, unload) |
| Load dwell time: | 1 - 999 sec (1 sec increment) |
| XY stage | |
| Stage size: | 100x100mm |
| Travel range: | 25x25mm, with digimatic micrometer heads |
| Resolution: | 0.001mm |
| Max. specimen height: | 133mm |
| Max. specimen depth: | 160mm (from the center of indenter) |
| Indenter/objective turret: | Motor driven and manual operation |
| Indenter mounting: | 2 positions |
| Objective mounting: | 4 positions |
| Optical path: | 2-way (measurement / exposure) |
| Resolution: | 0.01μm |
| Data output: | RS-232C, Digimatic code (SPC) and Centronics |
| Power supply: | 100/120/220/240V AC, 50/60Hz |
| Dimensions (W x D x H): | 400x640x600mm |
| Mass: | 43kg |

Optional Accessories

- 19BAA061:** Diamond indenter for Knoop (HM-211)
- 810-017:** Vise (max. opening: 100mm)
- 810-013:** Specimen (thin plate) holder
- 810-085:** Adjustable specimen (thin plate) holder
- 810-014:** Specimen (wire) holder
- 810-015:** Specimen (wire or ball) holder
- 810-019:** Specimen tilting holder
- 810-020:** Universal specimen holder
- 810-084:** Rotatable universal specimen holder
- 810-018:** Rotary table
- 810-622:** Printer (DPU-414)
- 19BAA157:** Printer paper (10-roll set)
- 19BAA266:** Connecting cable for printer
- 264-504:** DP-1VR
- 09EAA082:** Printer paper for DP-1VR (10-roll set)
- 936937:** SPC cable (1m)
- 965014:** SPC cable (2m)
- 19BAA001:** Hardness test block (100HV)
- 19BAA002:** Hardness test block (200HV)
- 19BAA003:** Hardness test block (300HV)
- 19BAA004:** Hardness test block (400HV)
- 19BAA005:** Hardness test block (500HV)
- 19BAA006:** Hardness test block (600HV)
- 19BAA007:** Hardness test block (700HV)
- 19BAA008:** Hardness test block (800HV)
- 19BAA009:** Hardness test block (900HV)
- 19BAA010:** Hardness test block (40HV)
- 810-641:** Vibration damping stand
- 11AAA002:** EXPACK data processing program

Consumable Parts

- 19BAA207:** Illumination lamp (1 pc.)



Refer to the HM-200 leaflet (E4308) for more details.

SYSTEM UPGRADE DIAGRAM

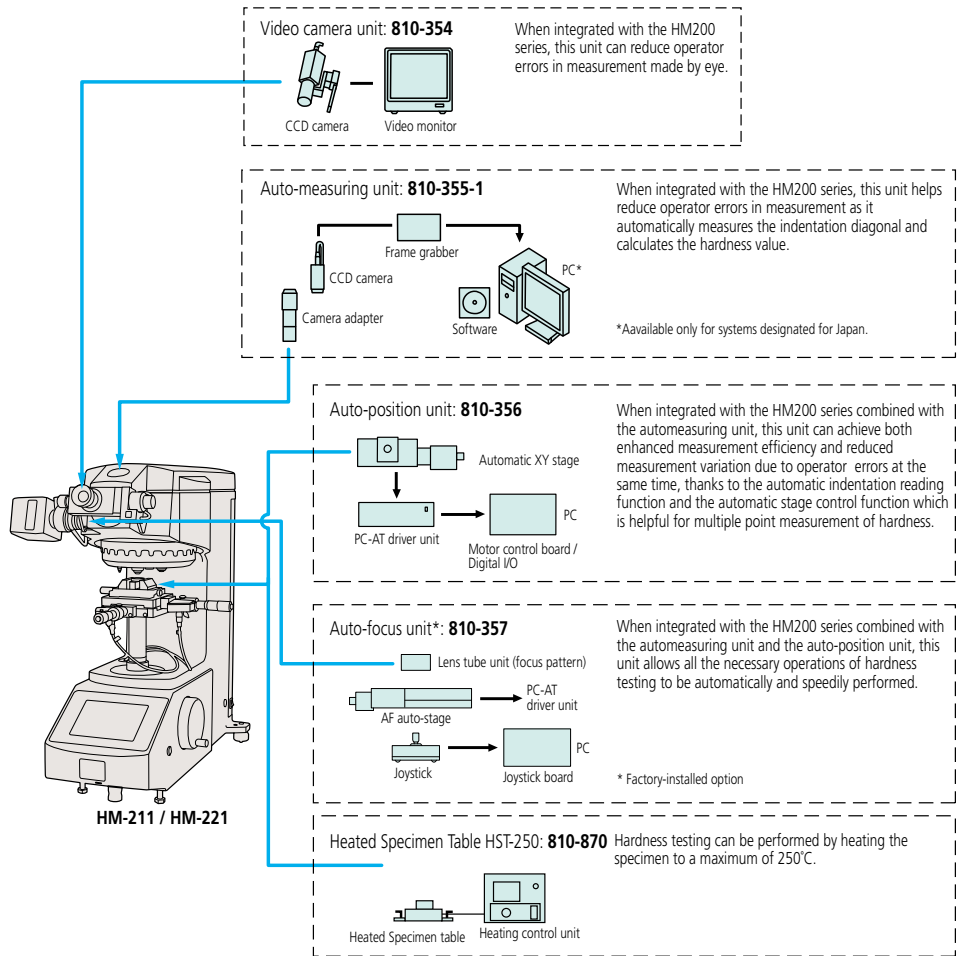

Note

- When building in the video camera unit, remove the eyepiece unit of the measuring microscope (standard accessory). If the Auto-measuring unit is added, it will be exclusively used in place of the measuring microscope or video camera unit. For the exclusive use of the Auto-measuring unit or video camera unit, an optional camera power unit (Order No. 19BAA360) is required. If the Auto-focus unit is added, the focus line is visible within the view field of the measuring microscope.
- The XY stage (digital type, standard accessory) is dismantled if the Automatic XY stage is to be used. Therefore, if the Auto-position unit is added and only the hardness tester is used, XY position data cannot be obtained.

HM-211 / HM-221



HM-101 / 102 / 103 / 112 / 113

SERIES 810 — Micro Hardness Testing Machines

FEATURES

- The load dwell time can be set in 1sec increments between 5 and 99sec*.
- A measuring resolution of 0.01μm* is provided that allows small indentations to be measured with high precision.

*HM-112, HM-113

HM-102
Economical digital type



HM-103
The TV monitor removes fatigue in visual measurement, reducing measurement errors.



HM-101
Economical manual type



HM-112
Digital display of measurement results and a statistical calculation function.



HM-113
Reduce individual differences in visual measurement with the TV monitor. The statistical calculation function reduces operation time.



Durable sheet-switch type

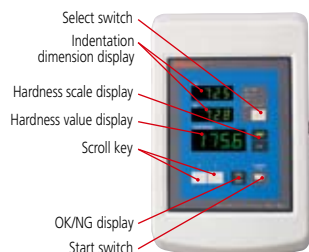

Touch-screen type

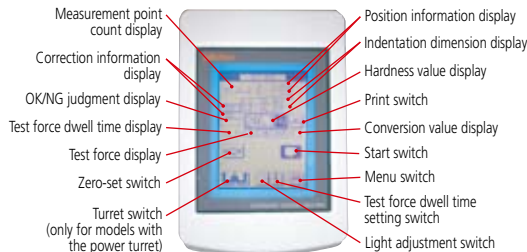

SPECIFICATIONS

| Model No. | HM-101 | HM-102 | HM-103 | HM-112 | HM-113 |
|---------------------------|--|---------------------------|-----------------|-------------------|-----------------|
| Order No. | 810-124* | 810-125* | 810-959* | 810-126* | 810-969* |
| Test force range | 98.07, 245.2, 490.3, 980.7, 1961, 2942, 4903, 9807mN | | | | |
| Test force setting | By dial | By dial | By dial | By dial | By dial |
| Control unit | — | Durable sheet-switch type | | Touch-screen type | |
| Video monitor | — | — | 9" B/W | — | 9" B/W |
| Indenter/objective turret | Manual type | Manual type | Manual type | Manual type | Manual type |
| Indenter mounts | 1 | 1 | 1 | 1 | 1 |
| Objective mounts | 1 (observation), 1 (measurement) | 2 (measurement) | 2 (measurement) | 2 (measurement) | 2 (measurement) |

* To denote your AC power cable add the following suffixes to the order No.:

A for UL/CSA, C for Taiwan, D for CEE, DC for CCC, E for BS, F for SAA, K for EK, No suffix is required for JIS/100V

Technical Data

| | |
|----------------------------|--|
| Test force range: | 98.07, 245.2, 490.3, 980.7, 1961, 2942, 4903, 9807mN |
| Test force setting: | By dial |
| Loading accuracy: | 1% (forces less than 9.807mN are ignored) |
| Load control: | Automatic (load, dwell, unload) |
| Load dwell time: | 5 - 30 sec: HM-101 5 - 60 sec: HM-102, HM-103 5 - 99 sec: HM-112, HM-113 |
| XY stage | |
| Stage size: | 100x100mm |
| Travel range: | 25x25mm, with micrometer heads |
| Resolution: | 0.01mm: HM-101, HM-102, HM-103 0.001mm: HM-112, HM-113 |
| Max. specimen height: | 95mm |
| Max. specimen depth: | 150mm (from the center of indenter) |
| Indenter/objective turret: | Manual type |
| Indenter mounting: | 1 position |
| Objective mounting: | 2 positions (10X, 50X) |
| Optical path: | 2-way (measurement / exposure) |
| Resolution: | 0.1μm (0.2μm: HM-101) |
| Data output: | RS-232C, Digimatic code (SPC) and Centronics |
| Power supply: | 100/120/220/240V AC, 50/60Hz |
| Dimensions (W x D x H) | |
| Main unit: | 410x600x590mm |
| Control unit: | 165x260x105mm |
| Mass (main unit): | 42kg |

Optional Accessories

- 810-017: Vise (max. opening: 100mm)
- 810-013: Specimen (thin plate) holder
- 810-085: Adjustable specimen (thin plate) holder
- 810-014: Specimen (wire) holder
- 810-015: Specimen (wire or ball) holder
- 810-019: Specimen tilting holder
- 810-020: Universal specimen holder
- 810-084: Rotatable universal specimen holder
- 810-018: Rotary table
- 810-622: Printer (DPU-414)
- 19BAA157: Printer paper (10-roll set)
- 19BAA266: Connecting cable for printer
- 19BAA102: Connecting cable for printer (HV-102)
- 264-504: DP-1VR
- 09EAA082: Printer paper of DP-1VR (10-roll set)
- 936937: SPC cable (1m)
- 965014: SPC cable (2m)
- 19BAA001: Hardness test block (100HV)
- 19BAA002: Hardness test block (200HV)
- 19BAA003: Hardness test block (300HV)
- 19BAA004: Hardness test block (400HV)
- 19BAA005: Hardness test block (500HV)
- 19BAA006: Hardness test block (600HV)
- 19BAA007: Hardness test block (700HV)
- 19BAA008: Hardness test block (800HV)
- 19BAA009: Hardness test block (900HV)
- 19BAA010: Hardness test block (40HV)
- 810-641: Vibration damping stand
- 11AAA002: EXPACK data processing program
- : VLPACK auto-reading measuring program (See page L-6.)

Consumable Parts

- 19BAA219: Illumination lamp (1 pc.)

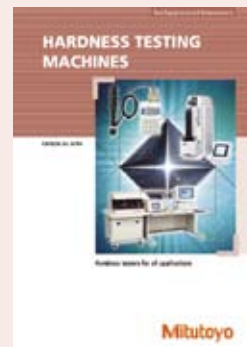

Refer to the Hardness Testing Machines leaflet (E4104) for more details.

AVK-CO, HV-112 / 113 / 114 / 115

SERIES 810 — Vickers Hardness Testing Machines

Technical Data

| | |
|----------------------------|--|
| Test force range | 9.807, 49.03, 98.07, 196.1, 294.2, 490.3N |
| AVK-CO: | |
| HV-112, HV-113: | 1.961, 2.942, 4.903, 9.807, 24.51, 49.03, 98.07, 196.1N |
| HV-114, HV-115: | 9.807, 19.61, 29.42, 49.03, 98.07, 196.1, 294.2, 490.3N |
| Test force setting: | By dial |
| Loading accuracy: | ±1% |
| Load control: | Automatic (load, dwell, unload) |
| Load dwell time: | 5s - 99s (1s increments) (5s, 10s, 15s, 20s, 30s: AVK-CO) |
| Max. specimen height: | 210mm (205mm: AVK-CO) |
| Max. specimen depth: | 170mm (165mm: AVK-CO) (from the center of indenter shaft) |
| Indenter/objective turret: | Manual |
| Indenter mounting: | 1 position |
| Objective mounting: | 2 positions (1 position: AVK-CO) |
| Optical path*: | Split two ways for video monitoring and photography (Single way: AVK-CO) |
| Resolution: | 0.1µm (1µm: AVK-CO) |
| Control unit*: | Touch-screen type |
| Data output*: | RS-232C, Digimatic code (SPC) and Centronics |
| Power supply: | 100/120/220/240V AC, 50/60Hz |
| Dimensions (W x D x H) | |
| Main unit: | 245x515x770mm |
| Control unit*: | 165x260x105mm |
| Mass (main unit): | 50kg (45kg: AVK-CO) |

*Except for AVK-CO

Optional Accessories

| | |
|------------------|---|
| 19BAA063: | Diamond indenter for Knoop |
| 810-037: | Round table (ø180mm) |
| 810-038: | Round table (ø250mm) |
| 810-012: | 50x50mm-travel XY stage |
| 810-016: | Vise (max. opening: 45mm) |
| 810-017: | Vise (max. opening: 100mm) |
| 810-622: | Printer (DPU-414) |
| 19BAA157: | Printer paper (10-roll set) |
| 19BAA266: | Connecting cable for printer |
| 264-504: | DP-1VR |
| 09EAA082: | Printer paper of DP-1VR (10-roll set) |
| 936937: | SPC cable (1m) |
| 965014: | SPC cable (2m) |
| 19BAA011: | Hardness test block (200HV) |
| 19BAA012: | Hardness test block (300HV) |
| 19BAA013: | Hardness test block (400HV) |
| 19BAA014: | Hardness test block (500HV) |
| 19BAA015: | Hardness test block (600HV) |
| 19BAA016: | Hardness test block (700HV) |
| 19BAA017: | Hardness test block (800HV) |
| 19BAA018: | Hardness test block (900HV) |
| 810-640: | Vibration damping stand |
| 11AAA002: | EXPAK data processing program |
| —: | VLPK auto-reading measuring program (See page L-6.) |

Consumable Parts

| | |
|-----------------|---------------------------|
| 810-087: | Illumination lamp (1 pc.) |
|-----------------|---------------------------|



Refer to the Hardness Testing Machines leaflet (E4104) for more details.

FEATURES

- A wide range of test force from 1.961N to 490.3N* is available for measuring various type of specimens. The load dwell time can be set in 1sec increments between 5 and 99sec. A measuring resolution of 0.1µm is provided that allows small indentations to be measured with high precision.

Function: Control unit

- Back-lit LCD graphic display for Indentation size (D1 and D2), Hardness value and scale, Number of measurement point
- Test conditions (HV / HK indenter type, test force, load dwell time), GO / ±NG tolerance judgment, Cylindrical and spherical surface compensation and offset
- Remote control of power turret
- Conversion to other hardness scales
- Statistical processing



SPECIFICATIONS

| Model No. | AVK-CO | HV-112 | HV-113 | HV-114 | HV-115 |
|---------------------------|---|---|-----------------|---|-----------------|
| Order No. | 810-160* | 810-163* | 810-981* | 810-165* | 810-985* |
| Test force range | 9.807, 49.03, 98.07, 196.1, 294.2, 490.3N | 1.961, 2.942, 4.903, 9.807, 24.51, 49.03, 98.07, 196.1N | | 9.807, 19.61, 29.42, 49.03, 98.07, 196.1, 294.2, 490.3N | |
| Test force setting | By dial | By dial | By dial | By dial | By dial |
| Control unit | — | Touch-screen type | | | |
| Video monitor | — | — | 9" B/W | — | 9" B/W |
| Indenter/objective turret | Manual operation | Motor driven | Motor driven | Motor driven | Motor driven |
| Indenter mounts | 1 | 1 | 1 | 1 | 1 |
| Objective mounts | 1 (measurement) | 2 (measurement) | 2 (measurement) | 2 (measurement) | 2 (measurement) |

* To denote your AC power cable add the following suffixes to the order No.:

A for UL/CSA, **D** for CEE, **DC** for CCC, **E** for BS, **F** for SAA, **K** for EK, **No suffix** is required for JIS/100V

AVK-HF: 810-155

Vickers hardness testing at high temperatures.



VLPAK2000

SERIES 810 — Auto-Reading Measuring Program

FEATURES

In hardness measurement the diagonal lines of the indentation must be measured on the TV monitor, which often results in varying measurements taken by different individuals. It also makes it difficult to save labor and increase efficiency.

- The high-speed auto-reader captures the indentation image and displays the hardness result in just 0.3 seconds, so the otherwise lengthy measuring work can be performed quickly.
- Complex multi-point measurement can be performed with ease.

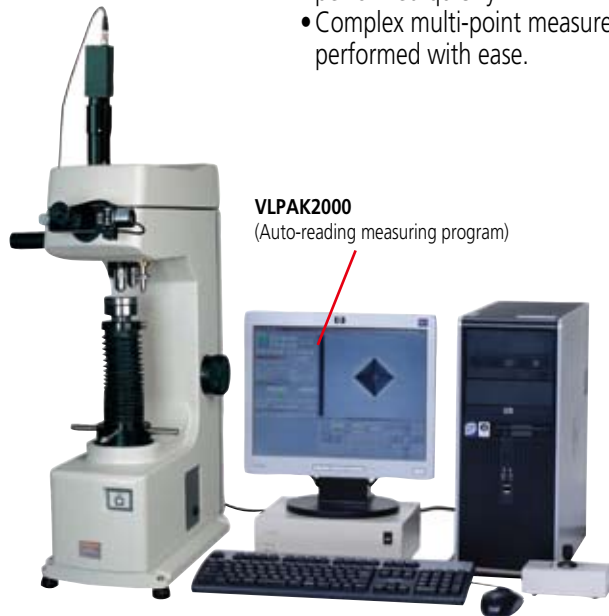

VLPK2000
(Auto-reading measuring program)

AT-400

SERIES 810 — Auto-Reading Hardness Testing System with automatic XY stage

FEATURES

The VLPK2000 auto-reading measuring program automatically reads the lengths of the indentation's diagonals and converts the result to a hardness value, thereby reducing operator-dependent measurement error. Moreover, the program's automatic high-speed reading function requires only 0.3 seconds to read hardness, which significantly improves work efficiency in hardness measurement.

- The movement pattern of the XY stage can be set to line, zigzag, matrix, circle, random, or combination.
- The learn function allows part programs to be easily created.
- Measurement conditions and positional data can be displayed on the monitor.
- The evaluation curves of case depth and hardness curves can be displayed on the monitor.

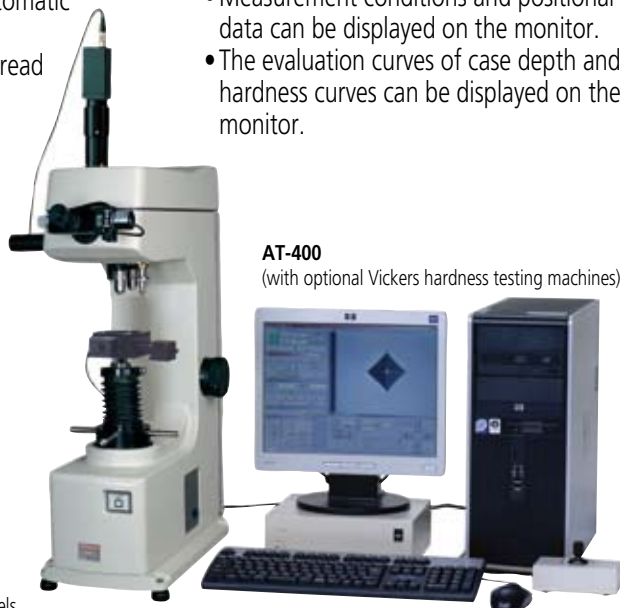

AT-400
(with optional Vickers hardness testing machines)

810-314-2*: For micro hardness models
810-314-12*: For Vickers hardness models

* To denote your AC power cable add the following suffixes to the order No.:

A for UL/CSA, C for Taiwan, D for CEE, DC for CCC, E for BS, K for EK, No suffix is required for JIS/100V

Technical Data

| | |
|------------------------------------|---|
| Automatic indentation measurement: | HV (Vickers) and HK (Knoop) |
| Measurement method: | Quadratic curve regression |
| Measurement time: | 0.3 seconds |
| Measurement reproducibility: | ±0.5% (0.1µm) (objective lens 50X, diagonal line 11 - 45mm, 500HV) |
| Manual measurement method: | Video line measurement of HV (Vickers) and HK (Knoop) |
| Conversion | |
| Hard steel: | HV, HK, HS, TENS, HRA, HRC, HRD, HR15N, HR30N, HR45N |
| Soft metal: | HV, HK, TENS, HRA, HRF, HRB, HRG, HR15T, HR30T, HR45T |
| OK/NG judgment: | Calculated at measurement |
| Image save: | Available on each operation screen |
| Center marker: | Display function ON/OFF |
| Measurement data save: | Saved in text format (CSV format) Can be processed with data processing macros |
| Functions: | Power turret control, Test force dwell time control (5 to 99s), Illumination level switch (15 levels), Loading speed level switch (4 levels), Indentation control |

Technical Data

| | |
|----------------------------------|---|
| Automatic XY stage | |
| Movement range: | 50.8x50.8mm |
| Minimum pitch: | 0.001mm (1µm) |
| External dimensions (W x D x H): | 240x240x65mm |
| Measurement pattern: | Line, Staggered, 3-point staggered, Matrix, Circle / arc, Random pattern, Teaching pattern, Combination pattern |
| Setting point count: | Max. 1000 points |
| Auto-reading function: | Refer to the above Technical Data of VLPK2000. |

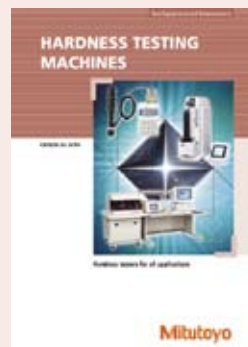

Refer to the Hardness Testing Machines leaflet (E4104) for more details.

AAV-500

SERIES 810 — Automatic Vickers Hardness Testing System

Technical Data

Automatic indentation measurement
 Measurement reproducibility: $\pm 0.5\%$ ($0.1\mu\text{m}$)
 Measurement method: Quadratic curve regression
 Measuring time: 0.3 seconds
 Resolution: $0.1\mu\text{m}$
 Manual measurement function: Measurement method with video line
 X-Y automatic stage
 Stage area: 130x130mm
 Movement range: 50x50mm
 Minimum step: $1\mu\text{m}$
 Software functions
 Patterned measurement: Line, staggered, 3-point staggered, matrix, circle, arc, random
 Teaching measurement pattern setting
 Hardness calculation function
 Hardness conversion function
 OK/NG judgment
 Analysis software functions: Device condition display, Measurement data display, Statistical calculation, Graph display
 Dimensions (W x D x H) / Mass
 AAV-503 / AAV-504: 665x516x1000mm / 91kg

FEATURES

This system can perform all operations required in the Vickers and Knoop hardness tests such as loading, turret indexing,

focusing, indentation measurement, and measurement position movement in full automatic, so it is optimal for the labor saving requirements of your test environment.



AAV-503 / AAV-504

- An indentation dimension automatic measuring time of 0.3 seconds is achieved (when a PC with recommended specifications is used), which dramatically improves operation efficiency.
- Measurement reproducibility of $\pm 0.5\%$ is achieved (For objective lens 50X, diagonal line 11 to 45mm, and 500HV), which provides reliable and stable test results.
- All operations from test condition setting to test result analysis can be performed on a Windows PC. In addition, data processing for the test results can be performed by using spreadsheet software.

The AAV-500 Series reduces individual differences in indentation dimension measurement in the Vickers hardness test by adopting special image analysis technologies. In addition, improved precision and high speed have been realized with a measuring time of just 0.3 seconds.

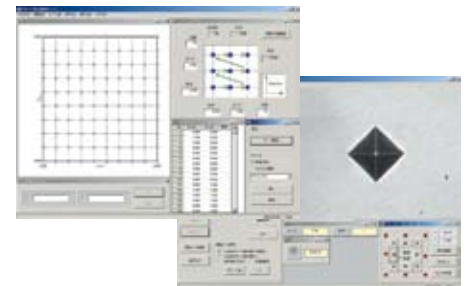

SPECIFICATIONS

| Model No. | AAV-503 | AAV-504 |
|-----------------------------|-----------------------------------|-----------------------------------|
| Order No. | 810-727* | 810-728* |
| Test force range | 1.961 - 196.1N | 9.807 - 490.3N |
| Test force switching | Manual | Manual |
| Objectives | 10X / 20X | 10X / 20X |
| Measurable indentation size | 40 - 400 / 20 - 100 μm | 40 - 400 / 20 - 100 μm |
| Resolution | $0.1\mu\text{m}$ | $0.1\mu\text{m}$ |

* To denote your AC power cable add the following suffixes to the order No.:
A for UL/CSA, **D** for CEE, **DC** for CCC, **E** for BS, **F** for SAA, **K** for EK, **No suffix** is required for JIS/100V

System Configuration

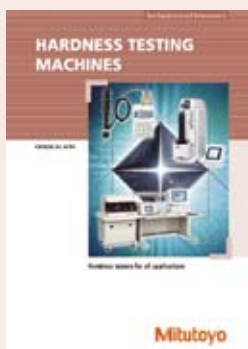
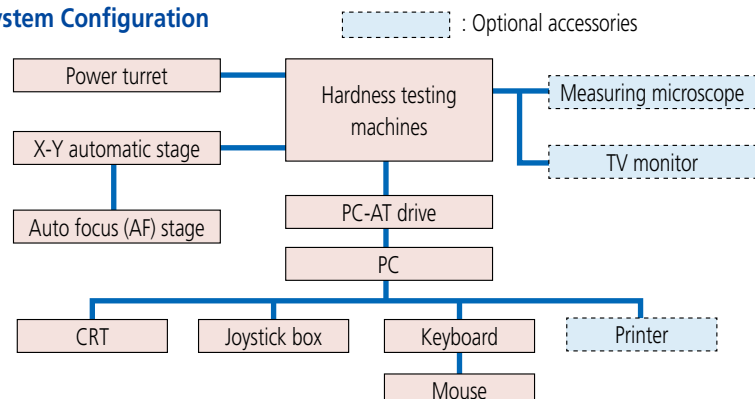

Refer to the Hardness Testing Machines leaflet (E4104) for more details.

HR-511 / 521 / 522 / 523

SERIES 810 — Rockwell Type Hardness Testing Machines

FEATURES

- Multiple test force generation for Rockwell, Rockwell Superficial and Brinell hardness.
- Dolphin-nose indenter arm for easy reach of interior (min. $\varnothing 40\text{mm}/\varnothing 22\text{mm}^*$) and exterior surfaces.
- *When using an optional diamond indenter (19BAA292).
- Real time electronic test force control for accurate loading. This perfectly eliminates load force overshoot.
- Indenter escape function for continuous testing at fixed table position. This eliminates instability caused by the table retraction.
- Auto-stop elevation table and automatic preliminary test force loading to provide stable test force generation.



Technical Data

Preliminary test force: 29.42N, 98.07N
 Test force
 Rockwell superficial: 147.1, 294.2, 441.3N
 Rockwell: 588.4, 980.7, 1471N
 Brinell*: 61.29, 98.07, 153.2, 245.2, 294.2, 306.5, 612.9, 980.7, 1226, 1839N

Test force setting: By control unit
 Load control: Automatic (load, dwell, unload)
 Load dwell time: 0s - 120s (1s increments)
 Max. specimen height: 205mm (for standard flat anvil)
 Max. specimen depth: 150mm (from the center of indenter shaft)

Stage elevation: Manual or power drive
 Control unit: Sheet-switch type or touch-screen type

Data output: RS-232C, Digimatic code (SPC) and Centronics

Power supply: 100/120/220/240V AC, 50/60Hz
 Dimensions (W x D x H)
 Main unit: 250x670x605mm
 Control unit: 165x260x105mm
 Mass (main unit): 65kg
 *HR-511, HR-521: 1839N only

Optional Accessories: See page L-9.

Various shapes of specimen can be tested. (Nose-type indenter axis mechanism has been adopted)

The nose-type indenter mechanism allows measurement of pipe samples as well as the top surface of a flat sample.

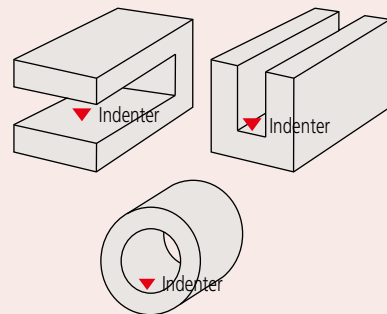

Function: Control unit

Durable sheet-switch type

- Durable sheet-switch operation with LED display.
- Remote selection of the test force linked to the hardness scale selection.
- Powerful statistical processing and 1024 data memory.
- Data offset
- OK / NG tolerance judgment.
- Statistical processing



Touch-screen type

- Touch-screen operation with a back-lit LCD graphic display.
- Remote selection of the test force linked to the hardness scale selection.
- Choice of message language in English, German, French, Spanish, Italian and Japanese for user-friendly operation.
- Cylindrical and spherical surface compensation.
- Data offset
- Conversion to other hardness scales.
- Powerful statistical processing with flexible data point editing and 1024 data memory.
- Measurement data editing
- OK/NG tolerance judgment.
- Statistical processing, histogram and X-R chart



SPECIFICATIONS

| Model No. | HR-511 | HR-521 | HR-522 | HR-523 |
|------------------------|---|-------------------|---|-------------------|
| Order No. | 810-208* | 810-202* | 810-203* | 810-204* |
| Preliminary test force | 29.42N, 98.07N | 29.42N, 98.07N | 29.42N, 98.07N | 29.42N, 98.07N |
| Test force | Rockwell superficial: 147.1, 294.2, 441.3N Rockwell: 588.4, 980.7, 1471N Brinell: 1839N | | Rockwell superficial: 147.1, 294.2, 441.3N Rockwell: 588.4, 980.7, 1471N Brinell: 61.29, 98.07, 153.2, 245.2, 294.2, 306.5, 612.9, 980.7, 1226, 1839N | |
| Test force setting | By control unit | By control unit | By control unit | By control unit |
| Stage elevation | Manual | Manual | Manual | Power drive |
| Control unit | Sheet-switch type | Touch-screen type | Touch-screen type | Touch-screen type |

* To denote your AC power cable add the following suffixes to the order No.:
 A for UL/CSA, D for CEE, DC for CCC, E for BS, F for SAA, K for EK, No suffix is required for JIS/100V

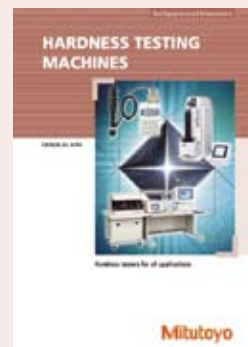

Refer to the Hardness Testing Machines leaflet (E4104) for more details.

HR-110MR / 210MR / 320MS / 430MR / 430MS

SERIES 963 — Rockwell Hardness Testing Machines

Optional Accessories

| | |
|-----------|--|
| 810-037: | Round tables (ø180mm) |
| 810-038: | Round tables (ø250mm) |
| 810-043: | Spot anvils (ø12mm) |
| 810-030: | Spot anvils (diamond tipped type for Rockwell Superficial) |
| 810-044: | Spot anvils (ø5.5mm) |
| 810-040: | V-anvils (ø40mm, 30mm groove width) |
| 810-041: | V-anvils (ø40mm, 6mm groove width) |
| 810-042: | V-anvils (ø10mm, 8mm groove width) |
| 810-029: | V-anvils (400mm length, 30mm groove width) |
| 19BA028: | Hardness test block (32HRB) |
| 19BA029: | Hardness test block (42HRB) |
| 19BA030: | Hardness test block (52HRB) |
| 19BA031: | Hardness test block (62HRB) |
| 19BA032: | Hardness test block (72HRB) |
| 19BA033: | Hardness test block (82HRB) |
| 19BA034: | Hardness test block (92HRB) |
| 19BA035: | Hardness test block (10HRC) |
| 19BA036: | Hardness test block (20HRC) |
| 19BA037: | Hardness test block (30HRC) |
| 19BA038: | Hardness test block (40HRC) |
| 19BA039: | Hardness test block (50HRC) |
| 19BA040: | Hardness test block (60HRC) |
| 19BA041: | Hardness test block (70HRC) |
| 19BA042*: | Hardness test block (41HR30N) |
| 19BA043*: | Hardness test block (50HR30N) |
| 19BA044*: | Hardness test block (60HR30N) |
| 19BA045*: | Hardness test block (73HR30N) |
| 19BA046*: | Hardness test block (83HR30N) |
| 19BA047*: | Hardness test block (75HR15N) |
| 19BA048*: | Hardness test block (85HR15N) |
| 19BA049*: | Hardness test block (90HR15N) |
| 19BA050*: | Hardness test block (32HR30T) |
| 19BA051*: | Hardness test block (42HR30T) |
| 19BA052*: | Hardness test block (52HR30T) |
| 19BA053*: | Hardness test block (62HR30T) |
| 19BA054*: | Hardness test block (72HR30T) |
| 19BA055*: | Hardness test block (78HR30T) |
| 19BA056*: | Hardness test block (82HR15T) |
| 19BA057*: | Hardness test block (87HR15T) |
| 19BAA124: | Hardness test block (40-50HRC) |
| 19BAA127: | Hardness test block (30-35HRB) |
| 19BAA128: | Hardness test block (64-69HR30N) |
| 19BAA150: | Hardness test block (36-40HR30T) |
| 264-504: | Printer (DP-1VR, 100V) |
| 937387: | Connecting cable (1m) |
| 19BAA161: | Measuring microscope (20X model) |
| 19BAA318: | Measuring microscope (40X model) |
| 19BAA319: | Measuring microscope (100X model) |
| 19BAA072: | Diamond indenter (For HR-***MR) |
| 19BAA073: | Diamond indenter (For HR-***MS) |
| 19BAA074: | Steel Ball indenter 1/6" |
| 19BAA075: | Steel Ball indenter 1/8" |
| 19BAA076: | Steel Ball indenter 1/4" |
| 19BAA077: | Steel Ball indenter 1/2" |
| 19BAA281: | Spare ø1mm carbide ball (1pc.) |
| 19BAA283: | Spare ø2.5mm carbide ball (1pc.) |
| 19BAA162: | Spare ø5mm carbide ball (1pc.) |
| 19BAA163: | Spare ø10mm carbide ball (1pc.) |

FEATURES

- The newly designed frame provides maximum clearance for positioning the workpiece. A flat table is all that is needed for mounting these testing machines.
- Simple to operate
With analogue type (HR-110MR, HR-210MR), the gauge presetting operation is unnecessary by the adoption of an automatic presetting dial gauge.
- HR-110MR does not require a power source, and is considered to be environmental friendly.
- The digital type (HR-430MR and HR-430MS), with the adoption of the automatic steering wheel brake & the automatic load sequence, with only simple handling test possibility.
- The digital type (HR-320MS, HR-430MR and HR-430MS) has digimatic output and our Digimatic Mini-Processor (DP-1VR) to print and input tools (USB-ITN-E) to connect to a PC and use for data transfer.
- Brinell hardness tests can be performed by using the following optional accessories: a Brinell indenter, a weight set and a measurement microscope.



HR-110MR

Rockwell hardness testing machine
Energy-saving model



HR-210MR

Rockwell hardness testing machine
Motor drive - Button start model



HR-320MS

Rockwell/Rockwell superficial hardness testing machine
Motor drive - Button start model



HR-430MR

Rockwell hardness testing machine
Motor drive - Automatic start model



HR-430MS

Rockwell/Rockwell superficial hardness testing machine
Motor drive - Automatic start model

SPECIFICATIONS

| Model No. | HR-110MR | HR-210MR | HR-320MS | HR-430MR | HR-430MS |
|---|---|---------------------------------|--------------------------------------|-----------------------------------|----------|
| Order No. | 963-210 | 963-220 | 963-231 | 963-240 | 963-241 |
| Type of hardness test | Rockwell | | | | |
| Standard | JIS B 7726 ISO6508-2 (ASTM E18) | | | | |
| Display | Analog | | Digital | | |
| Minimum reading | 0.5HR graduation | | 0.1HR indication | | |
| Preliminary test force (handling support) | Automatic pre-setting dial gauge | | Loading navigator indication | Automatic steering wheel brake | |
| Preliminary test force setting | — | | Dial switching | — | |
| Total test force setting | Weight change | | | Dial switching | |
| Total test force control | Manual | Motor drive - Button start | | Motor drive - Automatic start | |
| Test force duration | Manual | Fixed 3-5.5s or manual | | 3-60s setting or manual operation | |
| Maximum specimen height | 180mm (100mm if cover is attached) | | | | |
| Maximum specimen depth | 165mm (from indenter axis to the frame) | | | | |
| Function | — | | Success or failure decision function | | |
| | — | | Offset revision function | | |
| | — | | Hardness conversion function | | |
| Data output | — | | Digimatic (SPC), RS-232C | | |
| Power supply | No power required | | AC100-240V, 1.2A | | |
| Dimensions (W x D x H) | Approximately 296 x 512 x 780mm | Approximately 235 x 512 x 780mm | Approximately 235 x 516 x 780mm | | |
| Mass | Approximately 49kg | Approximately 47kg | Approximately 47kg | Approximately 50kg | |

MZT-500

SERIES 810 — Micro Zone Test System

When it comes to evaluating mechanical properties of ultra-small regions of ultra-fine specimens, the MZT-500 Series are exceptionally powerful tools in the fields of research and development and quality control. The MZT-500 can evaluate mechanical properties, which conventional hardness testing machines for fine specimens cannot measure, such as various CVD and PVD-deposited or generated films, including ion-plated

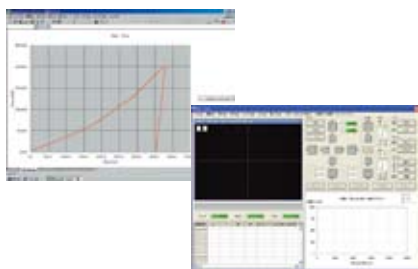

films; hardness of ultra-fine cross-sections; bonding mechanical properties; and wear mechanical properties of carbon fibers, glass fibers, whiskers, etc.



- Test data
The indentation factor can be obtained, which is related to the hardness value (partially) shown in Martens hardness test (ISO14577) and Young's modulus. Deformation characteristics in the load, dwell, and unload phases are also obtainable for use in determining properties of the specimen material.
- Hardness tests such as Vickers and Knoop hardness tests are supported.
- The balance lever vibration isolation mechanism reduces the effect of external vibrations on measurements.
- Indenter indentation depth can be measured up to a maximum of 20µm with a resolution of 0.1nm.
- Test forces between 0.1mN and 1000mN can be applied electromagnetically for evaluation of material properties in submicroscopic areas.
- Field-compatible form with cover for protection against dust and wind.

SPECIFICATIONS

| Model No. | MZT-500L | MZT-500P |
|--|-----------------|-----------------|
| Order No. | 810-813* | 810-814* |
| Basic system | ✓ | ✓ |
| Data analysis / control device | ✓ | ✓ |
| Manual type XY stage (Travel range 25x25mm) | ✓ | — |
| Automatic XY stage (Travel range: 50x50mm) | — | ✓ |

* To denote your AC power cable add the following suffixes to the order No.:
A for UL/CSA, **D** for CEE, **DC** for CCC, **E** for BS, **F** for SAA, **K** for EK,
No suffix is required for JIS/100V

| | |
|-----------------------------------|---|
| Test force loading device | Test force range: 0.1 to 1000mN |
| | Control resolution: 0.916µN |
| | Loading speed: 0.01 to 100mN/s |
| Indentation depth measurement | Range: 0 to 20µm |
| | Resolution: 0.1nm |
| Indenter | Type: Bercovici triangular pyramid indenter |
| Sample surface observation method | Camera: 1/3 inch black and white (410,000 pixels) |
| | Objective (monitor magnification): 100X (2500X), Optional: 10X (250X), 40X (1000X) |
| Specimen dimensions | Maximum height: 90mm |
| | Maximum depth: 90mm (From the center of the indenter axis) |
| Test type | Indentation test (with preliminary test force) |
| | Indentation test (without preliminary test force) |
| | Indentation depth setting test, continuous indentation test, repeated indentation test |

ABK-1

SERIES 810 — Hydraulic Brinell Hardness Testing Machines

The ABK-1 is a hydraulic Brinell hardness testing machines that is simple to operate and has high precision. This machine is suitable for hardness testing of raw materials, cast/forged components, and special steels.



FEATURES

- The anvil height adjusting handle uses a thrust bearing, providing smooth up/down operation.
- A large impression can create a smooth surface even when measuring on rough surfaces.
- A selection of loading weights is provided so that a test force from 4903N to 29420N can be applied to the indenter by means of a hydraulic balance. Two sizes of steel indenters, 10mm and 5mm, can be used according to the test requirements.

SPECIFICATIONS

| | |
|------------------|----------------|
| Model No. | ABK-1 |
| Order No. | 810-265 |
| Test force range | 4903 - 29420N |

Technical Data

| | |
|-------------------------|---|
| Test force: | 4903, 7355, 9807, 14710, 19614, 24517, 29420N |
| Test force application: | Manual |
| Test force control: | Manual (load, dwell, unload) |
| Test force dwell time: | Manual (arbitrary) |
| Specimen dimensions | |
| Maximum height: | 200mm |
| Maximum depth: | 155mm |
| Dimensions (W x D x H): | 430x510x1100mm |
| Mass: | 180kg |

Optional Accessories

- 19BAA162:** Carbide ball (ø5mm)
- 19BAA163:** Carbide ball (ø10mm)
- 19BAA071:** ø5mm steel ball (spare, 10pcs./set)
- 19BAA165:** ø10mm steel ball (spare, 5pcs./set)
- 19BAA166:** Hardness test block (200HB)
- 19BAA098:** Split level

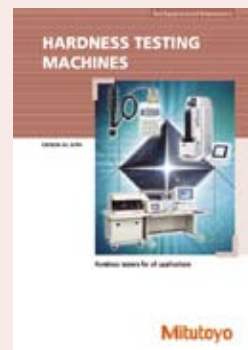

Refer to the Hardness Testing Machines leaflet (E4104) for more details.

ASH

SERIES 810 — Shore Hardness Testing Machines

Optional Accessories

- 19BAA205:** Roll testing stand
- 19BAA206:** Diamond hammer for general use
- 19BAA215:** Diamond hammer for rolls
- 810-090:** Measurement tube for general use
- 810-091:** Measurement tube for rolls

- 19BAA204:** Swing arm
Used for handling of large components over $\phi 100\text{mm}$ that cannot be measured using the main unit frame. It can be used easily by removing the measurement tube from the frame and installing it on the tip of the arm instead.



- 19BAA205:** Roll testing stand
Useful for measuring surface hardness of rolls over $\phi 100\text{mm}$ and other large workpieces that cannot be measured using the main unit frame. Can be used easily by removing the measurement tube from the standard frame and installing it in this frame instead.



- 19BAA202:** Diamond hammer
Optional spare for replacement of broken hammer.



- 19BAA203:** Hammer drawing tool
Used to remove the diamond hammer from the measurement tube.

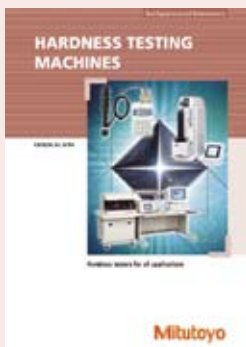

Refer to the Hardness Testing Machines leaflet (E4104) for more details.

The Shore hardness testing machines is designed for easy hardness measurement where the test machine and test method must be in compliance with the JIS standard. It is suitable for hardness testing of large, heavy, and difficult to move items such as rolls and for hardness measurement of final finish surfaces. It has a compact body that is easy to carry. By removing the measurement tube, it can be used to directly measure the hardness of the specimen.

FEATURES

- Easy to operate, allowing quick measurement.
- A small indentation depth makes product inspection possible.
- Capable of measuring a wide range of specimens, small to large. Many applications are possible with special accessories such as the swing arm and roll testing stand.

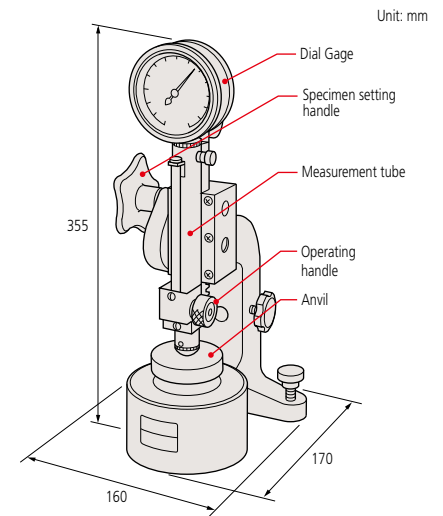
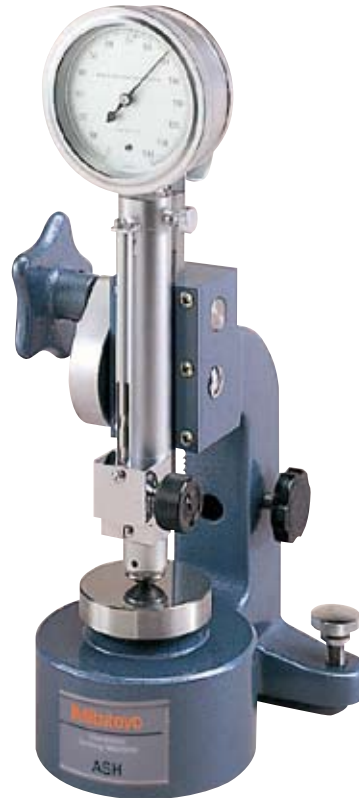

SPECIFICATIONS

| | | |
|-------------------------|---|-------------------------|
| Model No. | ASH-D0 | ASH-D1 |
| Order No. | 810-266 | 810-267 |
| Measurement target | General | Rolls |
| Standard | JIS D 7727 | |
| Dial range / graduation | 0 - 140HS / 1HS | |
| Tolerance (mean value) | ± 1.5 (35 to 95HS) | ± 1.0 (30 to 100HS) |
| Tolerance (dispersion) | 1.5 (less than 75HS) 2.0 (75HS or more) | 1.5 (30 to 100HS) |
| Specimen maximum height | 70mm | |
| Specimen maximum depth | 45mm (from the center of the indenter axis) | |
| Dimensions (W x D x H) | 160x170x355mm | |
| Mass | 16kg | |

Hardmatic HH-411

SERIES 810 — Impact Type Hardness Testing Unit

The HH-411 is a rebound type portable hardness tester for metal with a compact body and high operability. It allows anyone to perform hardness testing easily at the touch of a key, so it can be used widely on various types of workpiece in the field.



810-298: ASTM standard

810-299: JIS standard

Including the display unit, D type impactor (**810-287**) and carbide ball (**19BAA457**).

Rich variety of detectors available

In addition to the general-purpose detector (D type) supplied as standard equipment, the detector lineup includes rich variations (sold separately) to support special applications. The DC type is provided for hardness testing of internal walls of pipes with diameters that cannot be tested with the D type, the D+15 type for bearings and gears, and the DL type for small areas such as the bottom of small gears and weld corners.

Equipped with automatic orientation correction

For the rebound type hardness tester, gravity affects the measurement result depending on the orientation of the detector relative to the vertical when pressed against the specimen surface. The HH-411 is equipped with the latest measurement technology that automatically detects the orientation of the detector to automatically correct for this effect, so maximum accuracy is always achieved.

Hardness testing of small surfaces is possible

Only a small surface (standard D type: $\varnothing 22\text{mm}$, separately sold DL type: $\varnothing 4\text{mm}$) area on a workpiece is required for hardness testing. Therefore the HH-411 can be used for testing of various specimen shapes such as around grooves and gear teeth.

Equipped with a data save function

Up to 1800 hardness test results can be saved, which is useful for patrol tests in the field.

Hardness scale can be selected for your own individual purpose

Based on the hardness HL value (L value: according to ASTM A 956), conversion can be performed to Vickers, Brinell, Rockwell C, Rockwell B, and Shore hardness as well as tensile strength. Conversion can be performed after the test, or hardness value can be displayed in conversion mode.

Great operability

To operate, the detector is pressed against the sample surface and the detector button is pushed with a finger just like clicking a ballpoint pen, very easy for anyone to do.

Impactors (Optional accessories)

Various impactors can be connected to the display unit.



810-288

Use for inner walls of cylinders. The grip is short to allow easy positioning within a cylinder.



810-290

Use for gear teeth, welded corners, etc.



810-289

Use for concave workpieces such as gear teeth, ball bearing races, etc.

Technical Data

| | |
|-----------------------------|---|
| Impactor: | Impact hammer with integrated detector and carbide-ball tip (D type: conforming to ASTM A 956) |
| Display unit: | 7-segment LCD |
| Display range* / Resolution | Leeb: 1-999HL / 1HL |
| Conversion hardness display | Vickers: 43-950HV / 1HV |
| | Brinell: 20-894HB / 1HB |
| | Rockwell C: 19.3-68.2HRC / 0.1HRC |
| | Rockwell B: 13.5-101.7HRB / 0.1HRB |
| | Shore: 13.2-99.3HS / 0.1HS |
| | Tensile strength: 499-1996MPa / 1MPa |
| | *Display range depends on conversion table. |
| Functions: | Auto angle compensation, Offset, OK/NG judgment, Hardness scale conversion |
| | Data storage (1800 data entries) |
| | Statistical analysis (Average, Maximum, Minimum, Dispersion) |
| | Auto sleep function Impact counter display function |
| Testable workpiece | Thickness: Minimum 5mm |
| | Mass: 5kg or more |
| | Test points: 5mm or more from the edge of the sample, 3mm or more to each of the tested points. |
| | Surface roughness: Ra 2 μm or better |
| | Output: RS-232C, SPC |
| Power supply: | Alkaline AA battery 2pcs or optional AC adapter (battery life: 70 hours) |
| Size / Mass | Display unit: 70x110x35mm, 200g |
| | Impactor: $\varnothing 28 \times 175\text{mm}$, 120g |

Optional Accessories

- 264-504:** Digimatic Mini-Processor DP-1VR
- 937387:** Connecting cable for
- 09EAA082:** Printer paper (10 rolls/set)
- 810-622:** Thermal printer DUP-414
- 19BAA262:** Thermal printer connecting cable
- 19BAA157:** Thermal printer paper
- 19BAA238:** RS-232C connecting cable for PC
- 526688:** AC adapter of display unit
- 19BAA243:** Hardness test block (880HLD)
- 19BAA244:** Hardness test block (830HLD)
- 19BAA245:** Hardness test block (730HLD)
- 19BAA246:** Hardness test block (620HLD)
- 19BAA247:** Hardness test block (520HLD)
- 19BAA248:** Support ring for convex surface of cylinder (R10 - R20)
- 19BAA249:** Support ring for convex surface of cylinder (R14 - R20)
- 19BAA250:** Support ring for convex surface of sphere (R10 - R27.5)
- 19BAA251:** Support ring for concave surface of sphere (R13.5 - R20)
- 19BAA457:** Carbide ball for D, DC, D+15 type impactors
- 19BAA458:** Ball shaft for DL type impactor
- 810-287:** D type impactor UD-411
- 810-288:** DC type impactor UD-412
- 810-289:** D+15 type impactor UD-413
- 810-290:** DL type impactor UD-414
- 11AAA003:** EXPAK data processing program

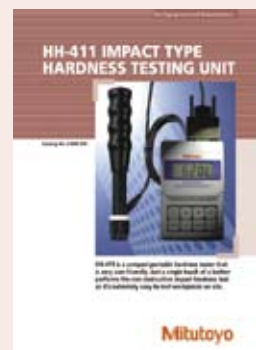

Refer to the HH-411 Impact Type Hardness Testing Unit leaflet (E4299) for more details.

Hardmatic HH-300

SERIES 811 — Durometers for Rubber and Plastics Hardness Testing

Technical Data

- Designed in accordance with the ASTM D 2240, ISO868, ISO 7619, DIN 53 505, JIS K 6253, and JIS K 7215 specifications.
- Units are available in both Shore A and Shore D scales, and suit a wide variety of applications.
- The Digital Durometer is provided with data hold function, permitting the operator to make an error-free reading on the LCD screen.
- The Dial Durometer is provided with a peak retaining hand for error-free reading.

Optional Accessories

- 19BAA180:** Holding bar*
- 811-019:** Testing stand (Shore A)
- 811-012:** Testing stand (Shore D)
- 811-013:** Testing stand (Shore A)**
- 811-014:** Testing stand (Shore D)**
- 811-017:** Auxiliary weights (Shore A)
- 811-018:** Auxiliary weights (Shore D)

*Only available on Compact Type Durometer.
**Long-leg Type Durometer attachment is included.

Testing stand applications

These stands are used to mount Durometers. They allow constant-pressure hardness measurement by ensuring that the Durometer presses vertically on the workpiece surface at all times.

- Anyone can perform repeatable hardness measurement due to fewer possibilities of human error and measurement variations.
- The supplied weights can be attached directly to a Durometer and allow constant-pressure hardness measurement of large samples for which a stand cannot be used.
- The supplied weights are used for calibrating the spring tension of Durometers.



- Workstage dimension: ø90mm
- Maximum specimen height: 90mm



Refer to the Hardmatic HH-300 leaflet (E4137) for more details.

FEATURES

Digital / Dial Durometers are suitable for testing the nature of the following materials — natural rubber, neoprene, polyesters, P.V.C., leather, Thiokol, nitrite rubber, wax, vinyl, cellulose acetates, glass polystyrene, etc.



SPECIFICATIONS

| Model No. | Digital | HH-336 | HH-336-01 | HH-332 | HH-338 | HH-338-01 | HH-334 |
|---------------------|--|----------------|-------------------|----------------|---|-------------------|----------------|
| | Dial | HH-335 | HH-335-01 | HH-331 | HH-337 | HH-337-01 | HH-333 |
| Order No. | Digital | 811-336 | 811-336-01 | 811-332 | 881-338 | 811-338-01 | 811-334 |
| | Dial | 811-335 | 811-335-01 | 811-331 | 881-337 | 811-337-01 | 811-333 |
| Scale | Shore A | | | Shore D | | | |
| Applications | Natural rubber, soft elastomers, etc. | | | | Hard elastomers, plastics, hard rubber, ebonite, etc. | | |
| Resolution | 0.5 (digital) or 1 (dial) | | | | 0.5 (digital) or 1 (dial) | | |
| Range | HA: 10 - 90 | | | | HD: 20 - 90 | | |
| Standards | ASTM D 2240 | ✓ | | ✓ | ✓ | | ✓ |
| | ISO 868 | ✓ | | ✓ | ✓ | | ✓ |
| | ISO 7619 | ✓ | | ✓ | ✓ | | ✓ |
| | DIN 53 505 | — | | ✓ | — | | ✓ |
| | JIS K 6253 | ✓ | | ✓ | ✓ | | ✓ |
| | JIS K 7215 | ✓ | | ✓ | ✓ | | ✓ |
| Pressure foot | 44x18mm | | ø18mm | | 44x18mm | | ø18mm |
| Spring force (mN) | 550+75H (Hardness reading: 10-90) | | | | 444.5H (Hardness reading: 20-90) | | |
| Indenter | Blunt taper (Tip diameter: 0.79mm) | | | | Sharp point (Tip curvature: 0.1±0.01mm) | | |
| Tip angle | 35°±0.25° | | | | 30°±0.5° | | |
| Indenter diameter | | | | | 1.25mm | | |
| Indenter protrusion | | | | | 2.5mm | | |
| Functions | Digital: Data hold, Zero -setting, SPC output, Power ON/OFF (Power supply: SR44 x 1 pc.) Analog Durometer: Peak retaining hand | | | | | | |
| Type | Compact | | Long-leg | | Compact | | Long-leg |
| Dimensions (WxDxH) | Digital | 60x28.5x151mm | | 60x28.5x193mm | | 60x28.5x151mm | |
| | Dial | 56x33.5x144mm | | 56x33.5x186mm | | 56x33.5x144mm | |
| Mass | Digital | 290g | | 310g | | 290g | |
| | Dial | 300g | | 320g | | 300g | |

L